

**TECHNICAL INFORMATION
AND
SERVICE DATA**



RADIOLAS

Models 515-M, 616-T & 716-C

**FIVE VALVE, TWO BAND, BATTERY/VIBRATOR
OPERATED SUPERHETERODYNES**

ISSUED BY

AMALGAMATED WIRELESS (A/SIA.) LTD.

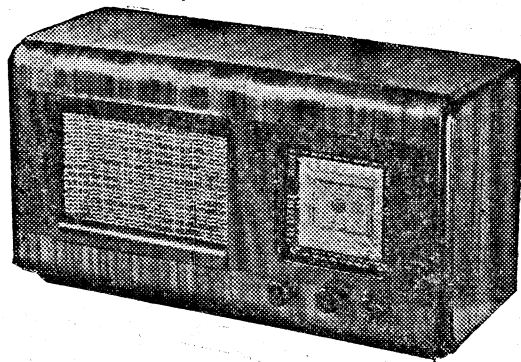

515-M

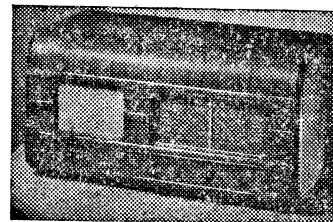

616-T

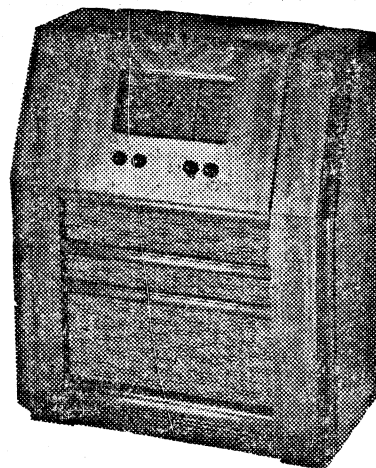

716-C

ELECTRICAL SPECIFICATIONS.

FREQUENCY RANGES:

Medium Wave 1600-540 Kc/s (187.5-555 M.)
Short Wave 18-6 Mc/s (16-50 M.)

INTERMEDIATE FREQUENCY 455 Kc/s

BATTERY COMPLEMENT:

	Cable with tips.	Cable with plugs.
(1) 1—4 volt accumulator (2) 2—45 volt "B" batteries	} 19183	19803
(1) 1—1.5 volt dry cell "A" battery (2) 2—45 volt "B" batteries		
	} 19182	19801

NOTE: If a 1.5 volt dry cell "A" battery is used, it is necessary, if dial illumination is required, to remove the dial lamp cable from the terminals on top of the chassis and to connect the cable to the outer terminals of a 4.5 volt battery—see diagram "Battery Connections."

VIBRATOR POWER UNIT OPERATION:-

1—4 volt accumulator.
Vibrator Power Unit No. 19190.

BATTERY CONSUMPTION:

4 volt "A" battery 0.2 amp.
1.5 volt "A" battery 0.3 amp.
"B" battery 16 mA
Vibrator operation 0.8 amp.

DIAL LAMP 6.3 volt, 0.25 amp.

FUSE:

Battery Operation 1-3/8 amp.
Vibrator Operation 3 amp.

D.C. RESISTANCE OF WINDINGS.

Windings.	D.C. Resistance in ohms.
Aerial Coil (M.W.)—	
Primary (L2)	18
Secondary (L3)	6
Aerial Coil (S.W.)	
Primary (L4)	3
Secondary (L5)	*
Oscillator Coil (M.W.)—	
Primary (L6)	*
Secondary (L7)	2
Oscillator Coil (S.W.)—	
Primary (L8)	*
Secondary (L9)	*
I.F. Transformer Windings	11
I.F. Filter (L1)	45†
L.T. Choke (L16)	*
Smoothing Choke (L75)	200
R.F. Filter Choke— (L73, L74)	*
R.F. Filter Choke— (L71, L72)	9
Loudspeaker Input Trans- former (T1)—	
XA8 Primary	425 or 510
XA8 Secondary	* *
TX31 Primary	380
TX31 Secondary	*
Vibrator Transformer— (T71)—	
Primary	*
Secondary	300

The above readings were taken on a standard chassis, but substitution of materials during manufacture may cause variations and it should not be assumed that a component is faulty if a slightly different reading is obtained.

* Less than 1 ohm.

† On some receivers this reading may be as high as 60 ohms.

VALVE COMPLEMENT:

- (1) 1R5 Converter.
- (2) 1T4 I.F. Amplifier.
- (3) 1T4 I.F. Amplifier.
- (4) 1S5 Detector, A.V.C., and A.F. Amplifier.
- (5) 3V4 Output.

CONTROLS:

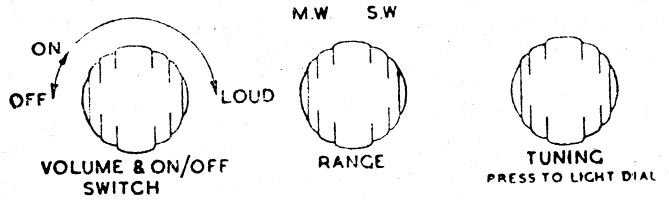

VIBRATOR A.W.A./OAK Type V6804

LOUDSPEAKER (Permanent Magnet):

Model 515M.

Model 616-T.

5 inch—code number AC32 7 inch—code number AY40
Transformer—XA8 Transformer—XA8

V.C. Impedance 3 ohms at 400 C.P.S. V.C. Impedance—3 ohms at 400 C.P.S.

Model 716C.

12 inch—code number AU29
Transformer—TX31

V.C. Impedance 12½ ohms at 400 C.P.S.

MODEL 515-M

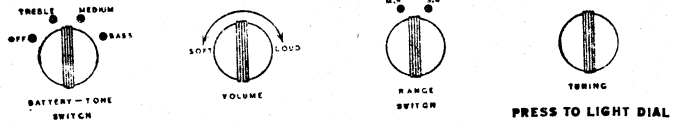

MODELS 616-T & 716-C

UNDISTORTED POWER OUTPUT 200 milliwatts

MECHANICAL SPECIFICATIONS.

Height. Width. Depth.

Cabinet Dimensions (inches)—

515-M	9¼	17¾	6¾
616-T	10½	19¾	8¾
716-C	32	30	13

Weight (nett lbs.)—

515-M	14
616-T	23
716-C	56

Chassis Base Dimensions (ins.)

2½	11	5½
----	----	----

Cabinet Finish—

515-M	Walnut Veneer
616-T	Walnut Veneer
716-C	Walnut Veneer

Carton Dimensions (inches)—

515-M	9½	17¾	8½
616-T	11	20	10¼
716-C	33	31¾	14¾

GENERAL DESCRIPTION.

The models 515-M, 616-T and 716-C are mantel, table and console models respectively. They may be either battery or vibrator operated and for battery operation either a 4-volt accumulator or a 1.5 volt dry cell "A" battery may be used, the necessary circuit modification being effected by the battery cable employed.

Battery connections are shown in the accompanying diagrams.

Design features include: Tropic-proof construction, automatic volume control, magnetite cores in I.F. transformers and broadcast oscillator coil, and air-dielectric trimming capacitors.

Models 616-T and 716-C employ straight-line edge lighted dials with metropolitan stations printed in 1/8" high characters.

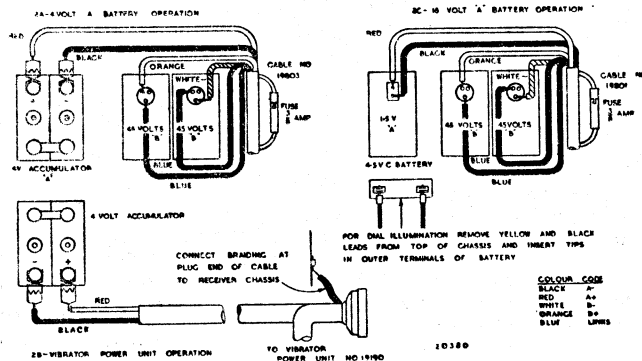

ALIGNMENT PROCEDURE.

Manufacturer's Setting of Adjustments.

The receiver is tested by the manufacturers with precision instruments, and all adjusting screws are sealed. Re-alignment should be necessary only when components in tuned circuits are repaired or replaced, or when it is found that the seals over the adjusting screws have been broken.

It is especially important that the adjustments should not be altered unless in association with the correct testing instruments listed below.

Under no circumstances should the plates of the ganged tuning capacitor be bent, as the unit is accurately aligned during manufacture and cannot be re-adjusted unless by skilled operators using specialised equipment.

For all alignment operations, connect the "low" side of the signal generator to the receiver chassis, and keep the

generator output as low as possible to avoid A.V.C. action. Also, keep the volume control in the maximum clockwise position.

Testing Instruments.

- (1) A.W.A. Junior Signal Generator, type 2R3911
- or
- (2) A.W.A. Modulated Oscillator, type J6726.

If the modulated oscillator is used, connect an 0.25 megohm non-inductive resistor across the output terminals, and, for Short Wave alignment, an additional 400 ohms non-inductive resistor in series with the "high" output lead of the instrument.

- (3) A.W.A. Output Meter type 2M8832.

ALIGNMENT TABLE

Order.	Connect "high" side of Generator to	Tune Generator to	Set Receiver Dial to	Adjust for Maximum Peak Output.
1	Aerial section of gang (Rear Portion)	455 kc/s	540 kc/s	L14 (Core)
2	Aerial section of gang (Rear Portion)	455 kc/s	540 kc/s	L13 (Core)
3	Aerial section of gang (Rear Portion)	455 kc/s	540 kc/s	L12 (Core)
4	Aerial section of gang (Rear Portion)	455 kc/s	540 kc/s	L11 (Core)
5	Aerial section of gang (Rear Portion)	455 kc/s	540 kc/s	L10 (Core)
Repeat the above adjustments until the maximum output is obtained.				
6	Aerial Terminal	600 kc/s	600 kc/s	L.F. Osc. Core Adj. (L7)*
7	Aerial Terminal	1500 kc/s	1500 kc/s	H.F. Osc. Adj. (C5)
8	Aerial Terminal	1500 kc/s	1500 kc/s	H.F. Aer. Adj. (C2)
Repeat adjustments 6, 7 and 8.				
9	Aerial Terminal	16 mc/s	16 mc/s	H.F. Osc. Adj. (C7)†
10	Aerial Terminal	16 mc/s	16 mc/s	H.F. Aer. Adj. (C3)‡

* Rock the tuning control back and forth through the signal.

† Use the minimum capacity peak if two can be obtained. Check to determine that C7 has been adjusted to correct peak by tuning the receiver to approximately 15.09 mc/s, where a weaker signal should be received.

‡ Use maximum capacity peak if two can be obtained.

Loudspeaker Service.

It is inadvisable to attempt loudspeaker repairs other than replacement of the transformer. The fitting of a new cone should be done only by Service Departments suitably equipped to do the work.

Chassis Removal.

Models 515-M and 616-T.

First remove the knobs and felt washers—each knob is held by a set screw. Then, remove the two screws from underneath the cabinet and withdraw the chassis.

Model 716-C.

- (1) Remove the knobs and felt washers. The knobs are each held by set screws.
- (2) Disconnect the loudspeaker cable.
- (3) The chassis is held in the cabinet by four winged nuts, two at each end of the dial frame assembly. Removal of these enables the chassis to be withdrawn from the cabinet.

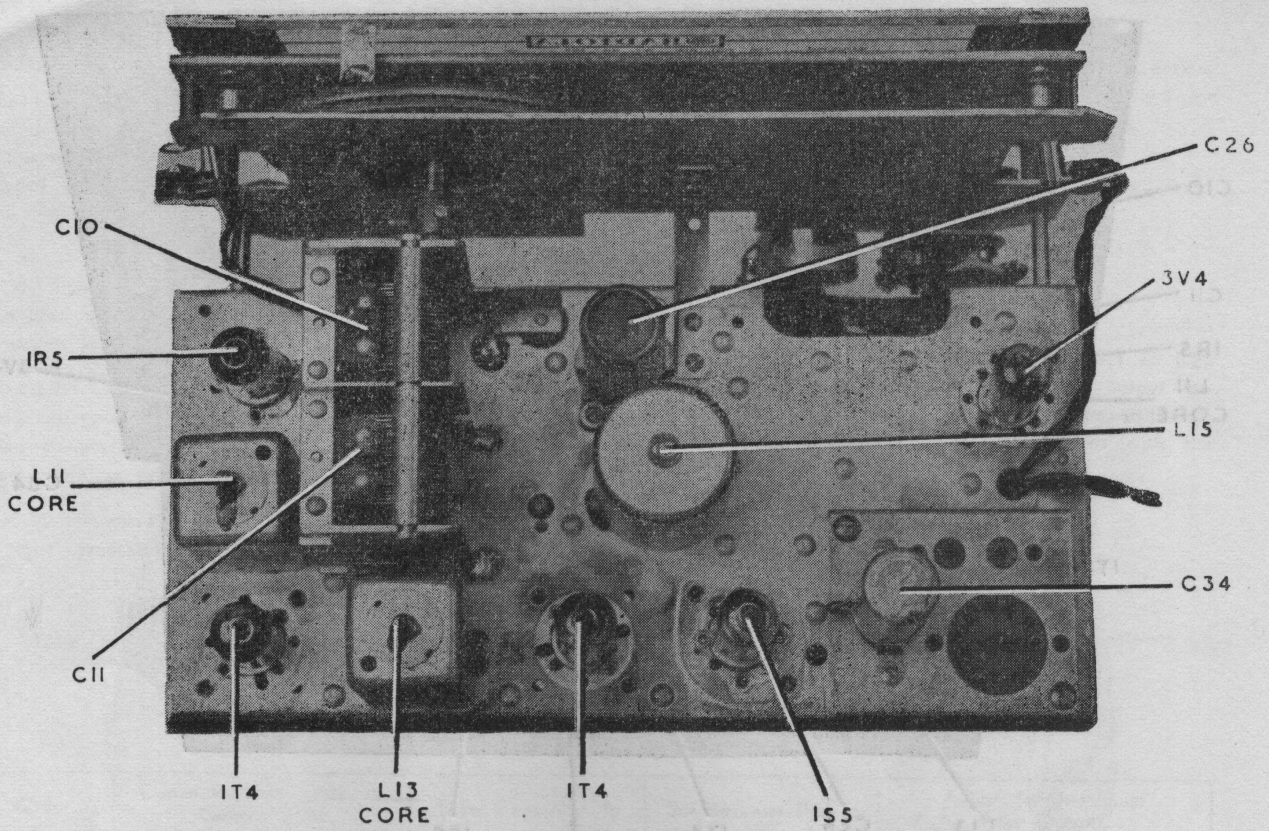

CHASSIS (TOP VIEW) MODEL 616-T

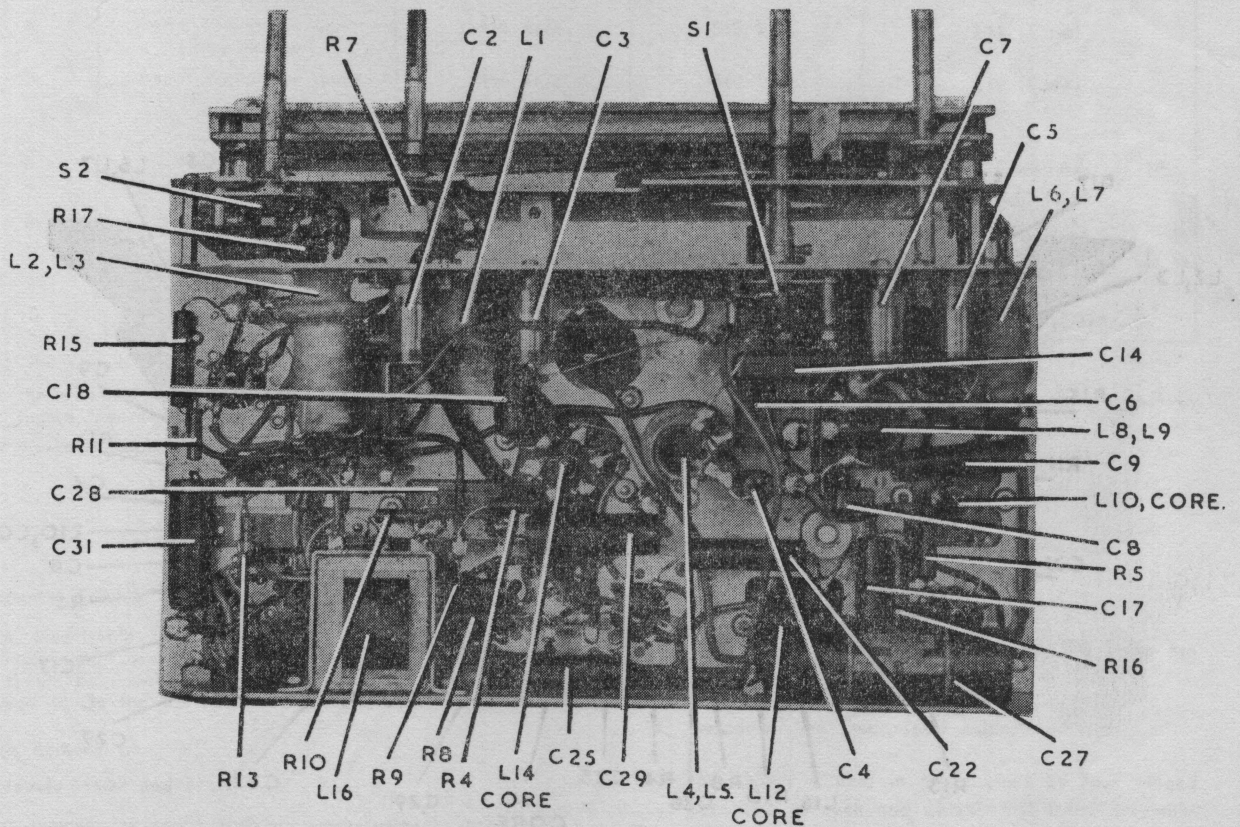

CHASSIS (UNDERNEATH VIEW) MODEL 616-T

Dial Pointer Adjustment.

Model 515-M.

To shift the position of the dial pointer, loosen two screws in the rear of the drive drum—see accompanying diagram—move the drum to the required position, and re-tighten the screws.

Models 616-T and 716-C.

The dial pointer is held in position on the drive cord by two rubber-lined clips. To alter the position of the

pointer, loosen the holding clips slightly and move the pointer in the required direction. It is important to re-clip the clips after any adjustment of the dial pointer.

To replace the tuning drive cord, follow the diagram which is affixed to the back of the dial frame assembly. This shows the route of the cord and the method of attachment.

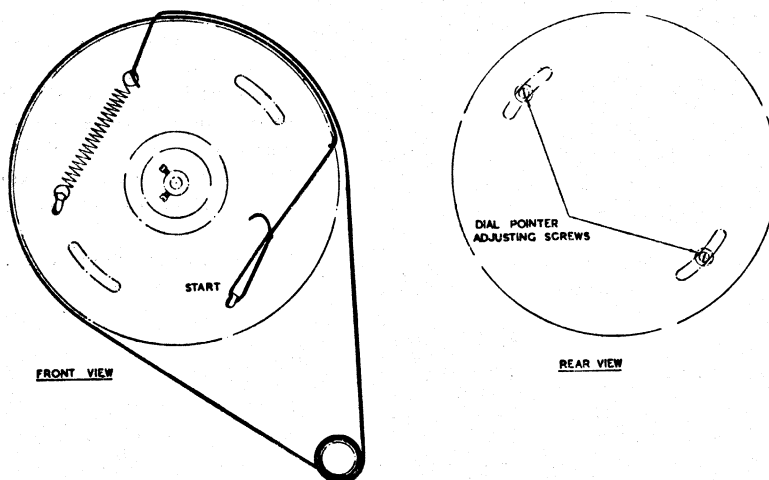

SOCKET VOLTAGES

Valve.	Bias Volts.		Screen to Chassis Volts.		Anode to Chassis Volts.		Anode Current mA.		Filament Volts.
	B.	V.	B.	V.	B.	V.	B.	V.	
IR5 Converter	0	0	55*	55*	55*	55*	1.1	1.1	1.3—1.4
IT4 I.F. Amp.	0	0	35*	35*	85	87	1.4	1.4	1.3—1.4
IT4 I.F. Amp.	0	0	35*	35*	85	87	1.4	1.4	1.3—1.4
IS5 Detector	0	-1.4	25†	35†	20†	20	0.06	0.06	1.3—1.4
3V4 Output	-5	-4.5	85	87	80	82	7.5	8	1.3—1.4

Measured with no signal input. Volume Control maximum clockwise.

* These readings may vary depending on the resistance of the voltmeter used.

† Cannot be measured with an ordinary voltmeter.

MECHANICAL REPLACEMENT PARTS

Item.	Part No.	Item.	Part No.
Cabinet, 515-M	C76	Drive Drum Assembly—	
Cabinet, 616-T	C83	515-M	20130
Cabinet, 716-C	C81	616-T	20130
Cable, battery—		716-C	15684
4 volt	19183	Knob—	
1.5 volt	19182	515-M	17603
Cable, loudspeaker (616-T, 716-C		616-T	4589
only)	19188	716-C	4589
Cable, volume control	15928	Socket, valve	19965
Chassis end—		Spindle, tuning drive—	
515-M, 616-T, Left-hand	20124	515-M	20650
Right-hand	22417	616-T	22634
716-C, Left-hand	20316	716-C	22388
Right-hand	20318	Strip tag—	
Dial Scale—		515-M, 2 way	8863
515-M	20008	3 way	8821
616-T	20524	5 way	15926
716-C	20334	616-T and 716-C—	
Dial Pointer Assembly—		1 way	7628
515-M	20132	2 way	8863
616-T	20522	2 way	8021
716-C	20331	5 way	15926
		Vibrator Power Unit	19190
		Terminal, aerial	17717

PLUGS VIEWED FROM WIRING SIDE.

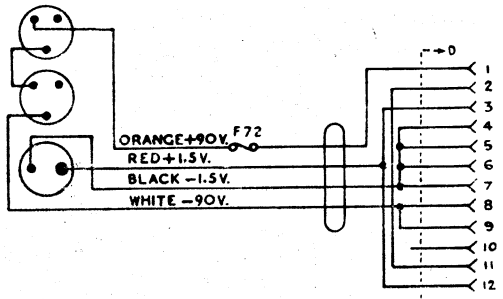

BATTERY CABLE
No. 19801

PLUGS VIEWED FROM WIRING SIDE

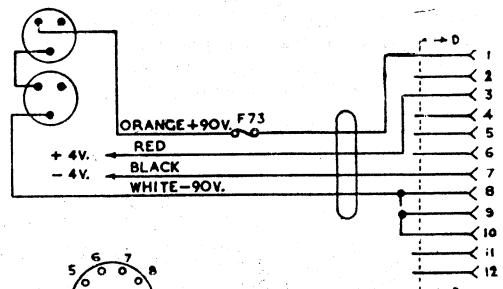

BATTERY CABLE
No. 19803

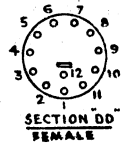

VIBRATOR POWER UNIT No. 19190

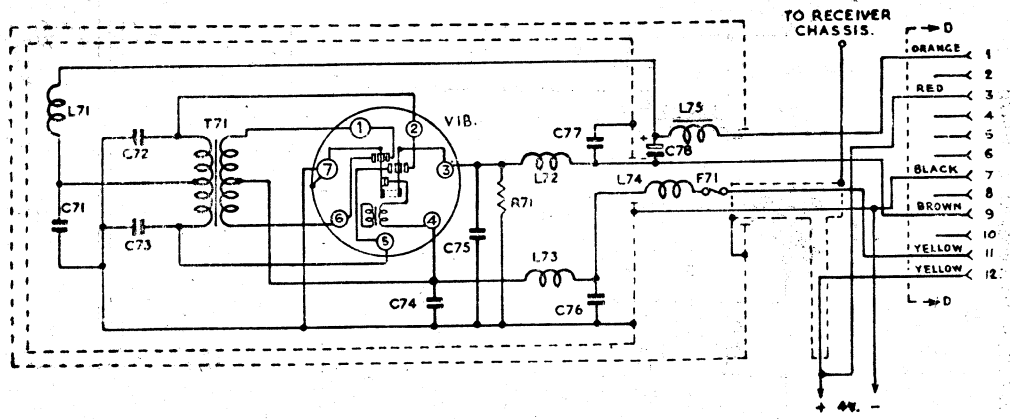

L71	R.F. choke	13809
L72	R.F. choke	13809
L73	R.F. choke	3149
L74	R.F. choke	3149
L75	R.F. choke	8321
R71	150 ohms, 1 watt, W.W.	
C71	0.01 uF paper, 600 V. working	
C72	0.02 uF paper, 600 V. working	
C73	0.02 uF paper, 600 V. working	
C74	0.1 uF paper, 400 V. working	
C75	0.01 uF paper, 600 V. working	
C76	0.1 uF paper, 400 V. working	
C77	0.01 uF paper, 600 V. working	
C78	20 uF, 200 P.V. electrolytic	
T71	Vibrator transformer	17568

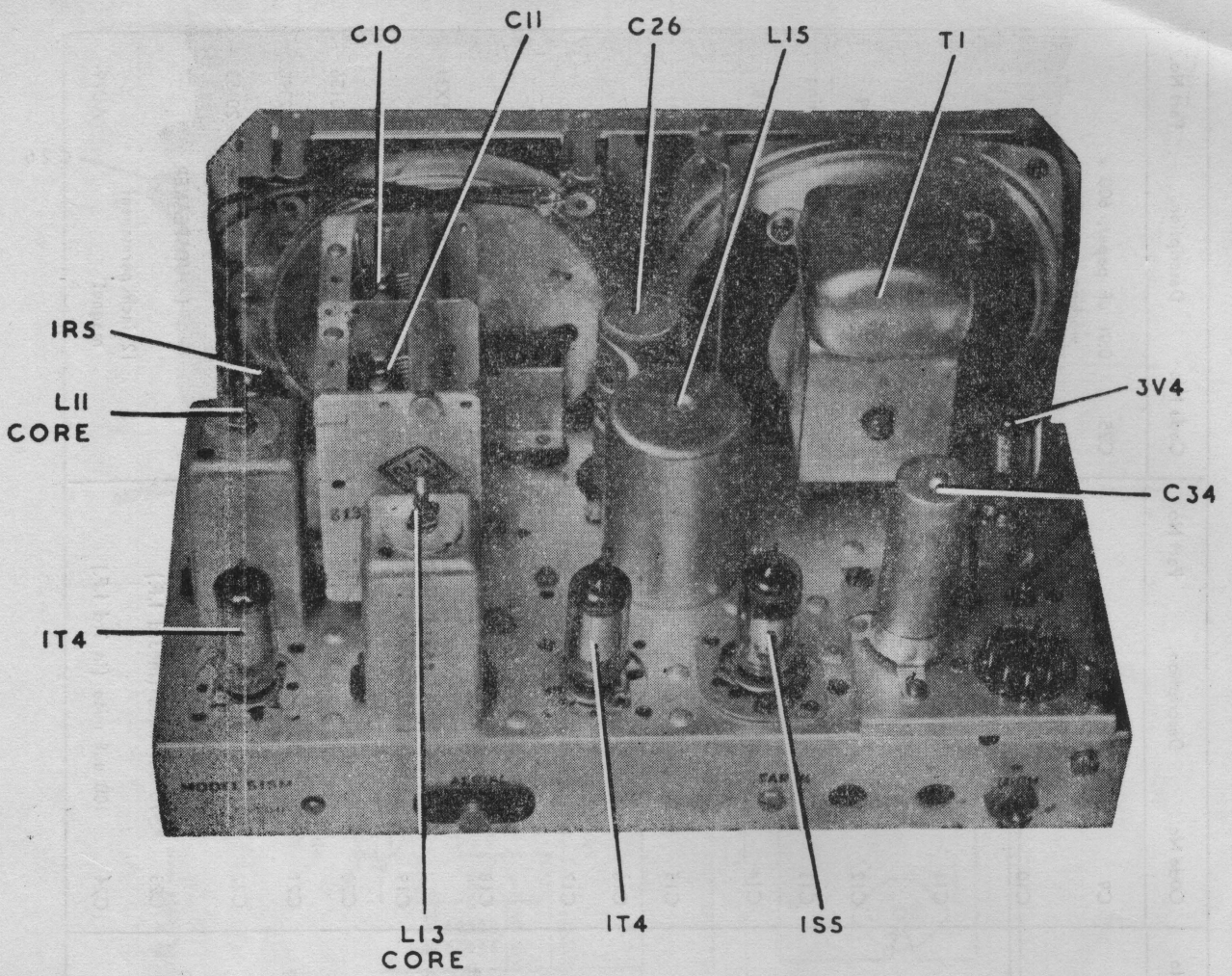

CHASSIS (TOP VIEW) MODEL 515-M

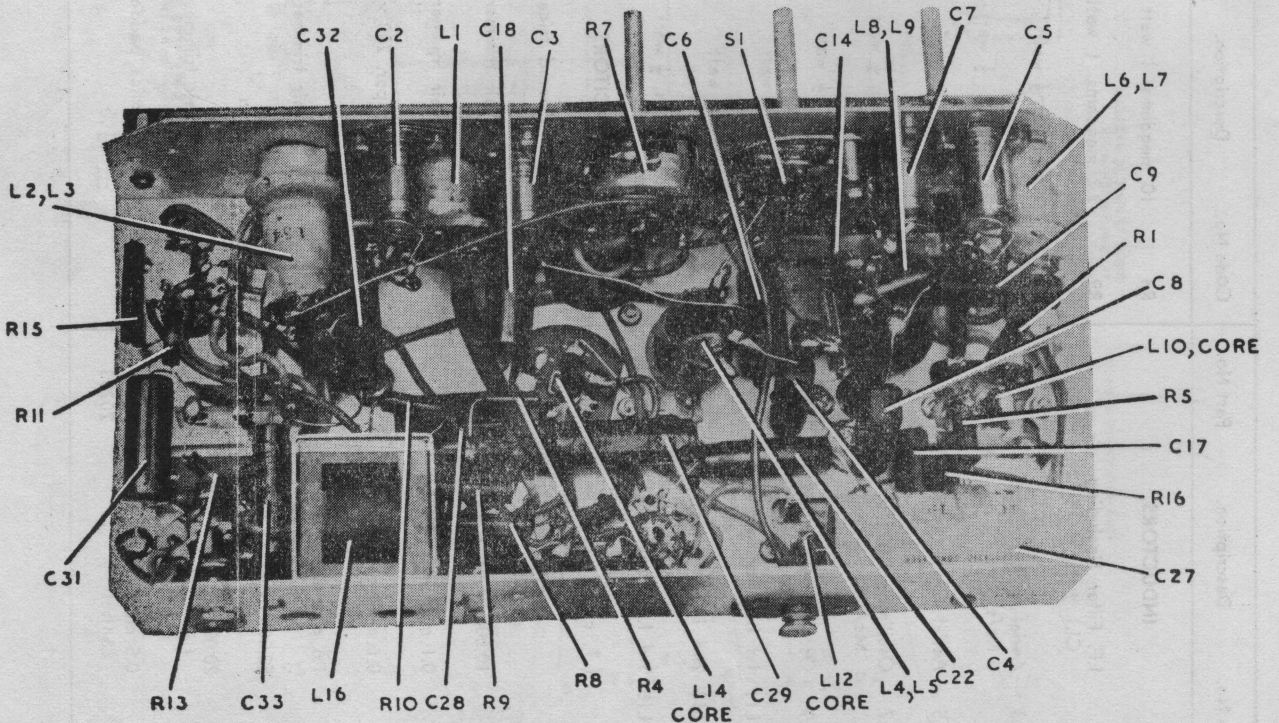

CHASSIS (UNDERNEATH VIEW) MODEL 515-M

CIRCUIT CODE - Model 515-M

CIRCUIT CODE — Model 716-C

Code No.	Description.	Part No.	Code No.	Description.	Part No.	Code No.	Description.	Part No.	Code No.	Description.	Part No.
	INDUCTORS.										
L1	I.F. Filter (including C.I.)	9382	R8	10 megohms, 1 watt		C9	0.05 uF paper, 200 v. working		C25	0.01 uF paper, 600 v. working	
L2, L3	Aerial Coil, 1600-540 Kc/s	15454	R9	3.2 megohms, 1 watt		C10	12-430 uuF tuning (ganged)	18286	C26	20 uF 200 P.V. Electrolytic	
L4, L5	Aerial Coil, 18-6 Mc/s	15456	R10	1 megohm, ½ watt		C11	12-430 uuF tuning (ganged)	18286	C27	400 uF 12 P.V.	
L6, L7	Oscillator Coil, 1600-540 Mc/s	9206A	R11	0.5 megohm, ½ watt		C12	Neutralising		C28	100 uuF mica	
L8, L9	Oscillator Coil, 18-6 Mc/s	15922	R12	320 ohms, ½ watt		C13	70 uuF mica		C29	0.1 uF paper, 200 v. working	
L10, L11	1st I.F. transformer	22416	R13	0.5 megohm, ½ watt		C14	470 uuF mica padder ± 2½%		C30	0.01 uF paper, 600 v. working	
L12, L13	2nd I.F. transformer	22416	R14	320 ohms, ½ watt		C15	70 uuF mica		C31	0.1 uF paper, 200 v. working	
L14, L15	3rd I.F. transformer	15483	R15	25 ohms, 1 watt		C16	70 uuF mica		C32	0.005 uF paper, 600 v. working	
L16	L.T. choke (audio)	XA18	R16	56 ohms, 1 watt		C17	0.05 uF paper, 200 v. working		C33	0.025 uF paper, 400 v. working	
	RESISTORS.		R17	10,000 ohms, ½ watt		C18	0.1 uF paper, 200 v. working		C34	400 uF 12 P.V.	
R1	10,000 ohms, ½ watt		C1	50 uuF silvered mica		C19	70 uuF mica			TRANSFORMER.	
R2	0.1 megohm, ½ watt		C2	3-25 uuF air trimmer	19659	C20	70 uuF mica		T1	Loudspeaker transformer	TX31
R3	0.1 megohm, ½ watt		C3	3-25 uuF air trimmer	19659	C21	100 uuF mica (in 3rd I.F.)		S1	Range Switch	20156
R4	1.6 megohm, ½ watt		C4	0.05 uF paper, 200 v. working		C22	0.05 uF paper, 200 v. working		S2	Battery/Tone Switch	22390
R5	50,000 ohms, ½ watt		C5	3-25 uuF air trimmer	19659	C23	70 uuF mica (in 3rd I.F.)		S3	Dial Lamp Switch	20153
R6	20,000 ohms, ½ watt (in 3rd I.F.)		C6	9 uuF mica		C24	100 uuF mica (in 3rd I.F.)			LOUDSPEAKER	
R7	0.5 megohm, volume control	20293	C7	3-25 uuF air trimmer	19659					12 inch permanent magnet	AU29
			C8	4000 uuF mica padder ± 2½%							

CIRCUIT DIAGRAM — Model 515-M

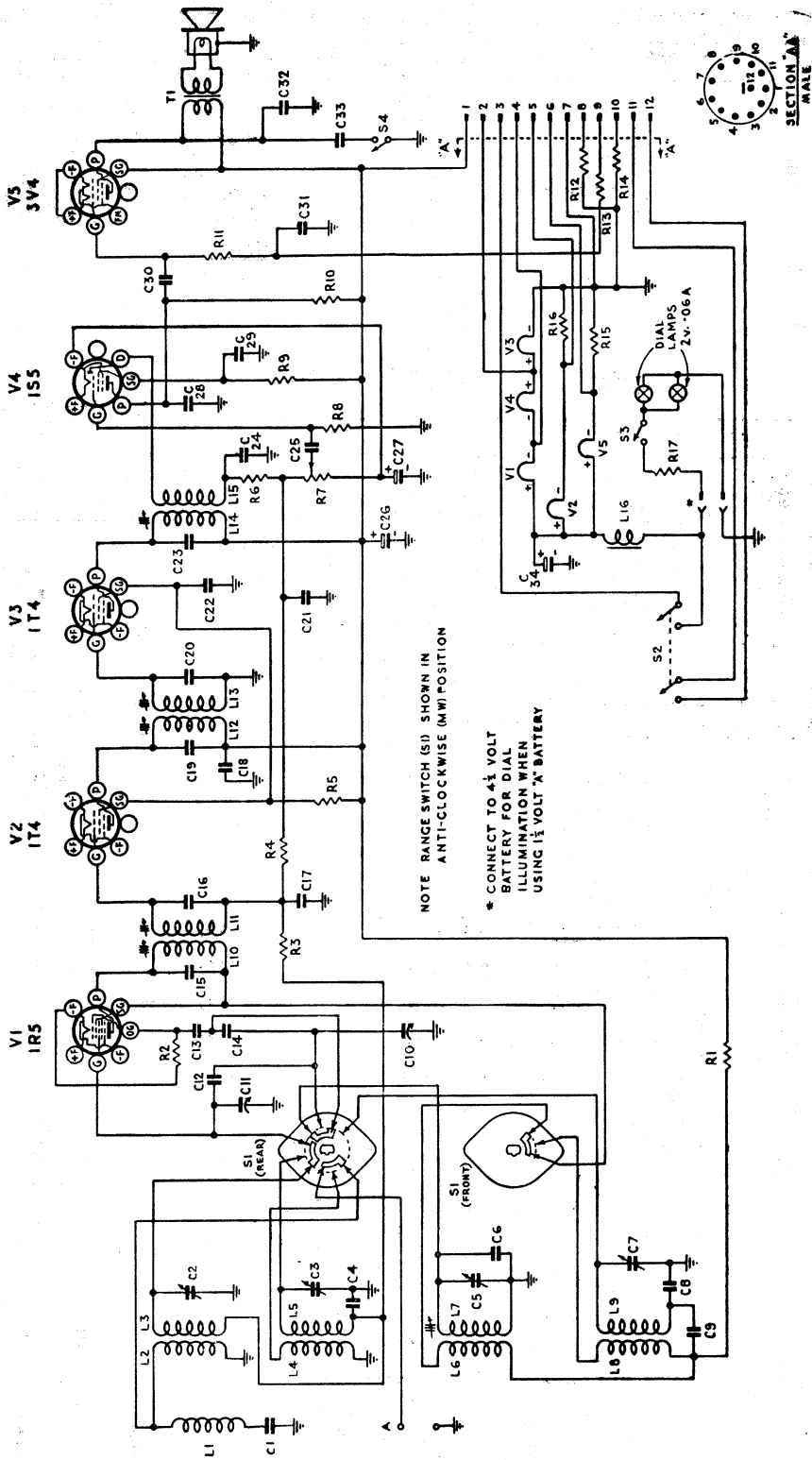

NOTE RANGE SWITCH (S1) SHOWN IN ANTI-CLOCKWISE (NMI) POSITION

* CONNECT TO 4½ VOLT BATTERY FOR DIAL ILLUMINATION WHEN USING ½ VOLT "A" BATTERY

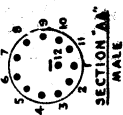

CIRCUIT CODE — Model 515-M

515-M, 616-T & 716-C

Code No.	Description	Part No.	Code No.	Description	Part No.
INDUCTORS.					
L1	I.F. Filter (including C1)	9382	C7	3-25 uuF air trimmer	19659
L2, L3	Aerial Coil, 1600-540 Kc/s	15454	C8	4,000 uuF mica	
L4, L5	Aerial Coil, 18-6 Mc/s	15456	C9	0.05 uF paper, 200 v. working	
L6, L7	Oscillator Coil, 1600-540 Kc/s	9206A	C10	12-430 uuF tuning (ganged)	18286
L8, L9	Oscillator Coil, 18-6 Mc/s	15922	C11	12-430 uuF tuning (ganged)	18286
L10, L11	1st I.F. Transformer	22416	C12	Neutralising	
L12, L13	2nd I.F. Transformer	22416	C13	70 uuF mica	
L14, L15	3rd I.F. Transformer	15483	C14	470 uuF mica	
L16	LT Choke (Audio)	XA18	C15	70 uuF mica	
RESISTORS.					
R1	10,000 ohms, 1 watt		C16	70 uuF mica	
R2	0.1 megohm, 1/2 watt		C17	0.05 uF paper, 200 v. working	
R3	0.1 megohm, 1/2 watt		C18	0.1 uF paper, 200 v. working	
R4	1.6 megohms, 1/2 watt		C19	70 uuF mica	
R5	50,000 ohms, 1/2 watt		C20	70 uuF mica	
R6	20,000 ohms, 1/2 watt (in I.F.)		C21	100 uuF mica (in I.F.)	
			C22	0.05 uF paper, 200 v. working	
			C23	70 uuF mica (in I.F.)	
			C24	100 uuF mica (in I.F.)	
			R7	0.5 megohm Volume Control	20293
			R8	10 megohms, 1 watt	
			R9	3.2 megohms, 1 watt	
			R10	1 megohm, 1/2 watt	
			R11	0.5 megohm, 1/2 watt	
			R12	320 ohms, 1/2 watt	
			R13	0.5 megohm, 1/2 watt	
			R14	320 ohms, 1/2 watt	
			R15	25 ohms, 1 watt	
			R16	56 ohms, 1 watt	
			R17	Not used.	
			CAPACITORS.		
			C1	50 uuF silvered mica	
			C2	3-25 uuF air trimmer	19659
			C3	3-25 uuF air trimmer	19659
			C4	0.05 uF paper, 200 v. working	
			C5	3-25 uuF air trimmer	19659
			C6	9 uuF mica	
			C25	0.01 uF paper, 600 v. working	
			C26	20 uF, 200 P.V. Electrolytic	
			C27	400 uF, 12 P.V.	
			C28	100 uuF mica	
			C29	0.1 uF paper, 200 v. working	
			C30	0.01 uF paper, 600 v. working	
			C31	0.1 uF paper, 200 v. working	
			C32	0.005 uF paper, 600 v. working	
			C33	0.025 uF paper, 400 v. working	
			C34	400 uF, 12 P.V.	
			TRANSFORMERS.		
			T1	Loudspeaker Transformer	XA8
			SWITCHES.		
			S1	Range Switch	20156
			S2	Battery Switch (inc. in R7)	
			S3	Dial Lamp Switch	20153
			S4	Tone Switch	20109
			LOUDSPEAKER.		
				5 inch Permanent Magnet	AC32

CIRCUIT DIAGRAM — Model 716-C

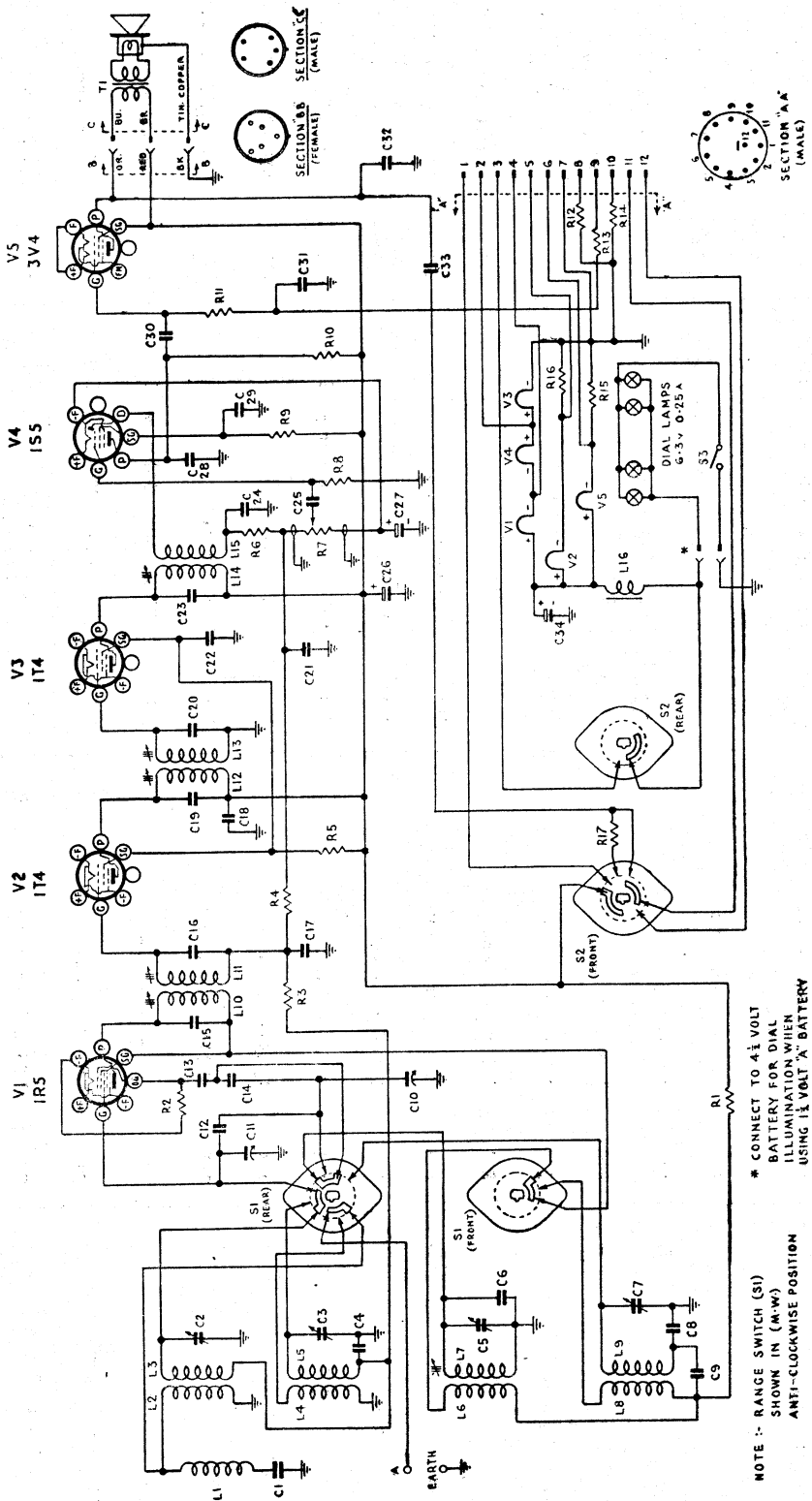

* CONNECT TO 4½ VOLT BATTERY FOR DIAL ILLUMINATION WHEN USING 1½ VOLT 'A' BATTERY

NOTE: RANGE SWITCH (S1) SHOWN IN (M-W) ANTI-CLOCKWISE POSITION

CIRCUIT DIAGRAM — Model 616-T

